



256-Kbit (32K x 8) nvSRAM with Real-Time-Clock

Features

- Data integrity of Cypress nvSRAM combined with full featured real time clock
 - Low power, 300 nA Max, RTC current
 - Capacitor or battery backup for RTC
- Watchdog timer
- Clock alarm with programmable interrupts
- 25 ns, 35 ns, and 45 ns access times
- "Hands-off" automatic *STORE* on power down with only a small capacitor
- *STORE* to QuantumTrap™ initiated by software, device pin, or on power down
- *RECALL* to SRAM initiated by software or on power up
- Infinite *READ*, *WRITE*, and *RECALL* cycles
- High reliability
 - Endurance to 200K cycles
 - Data retention: 20 years @ 55°C
- 10 mA typical I_{CC} at 200 ns cycle time
- Single 3V operation with tolerance of +15%, -10%
- Commercial and industrial temperature
- SSOP Package (ROHS compliant)

Functional Description

The Cypress CY14B256K combines a 256 Kbit nonvolatile static RAM with a full featured real-time-clock in a monolithic integrated circuit. The embedded nonvolatile elements incorporate QuantumTrap technology producing the world's most reliable nonvolatile memory. The SRAM can be read and written an infinite number of times, while independent, nonvolatile data resides in the nonvolatile elements.

The real-time-clock function provides an accurate clock with leap year tracking and a programmable, high accuracy oscillator. The alarm function is programmable for one time alarms or periodic seconds, minutes, hours, or days. There is also a programmable watchdog timer for process control.

Logic Block Diagram

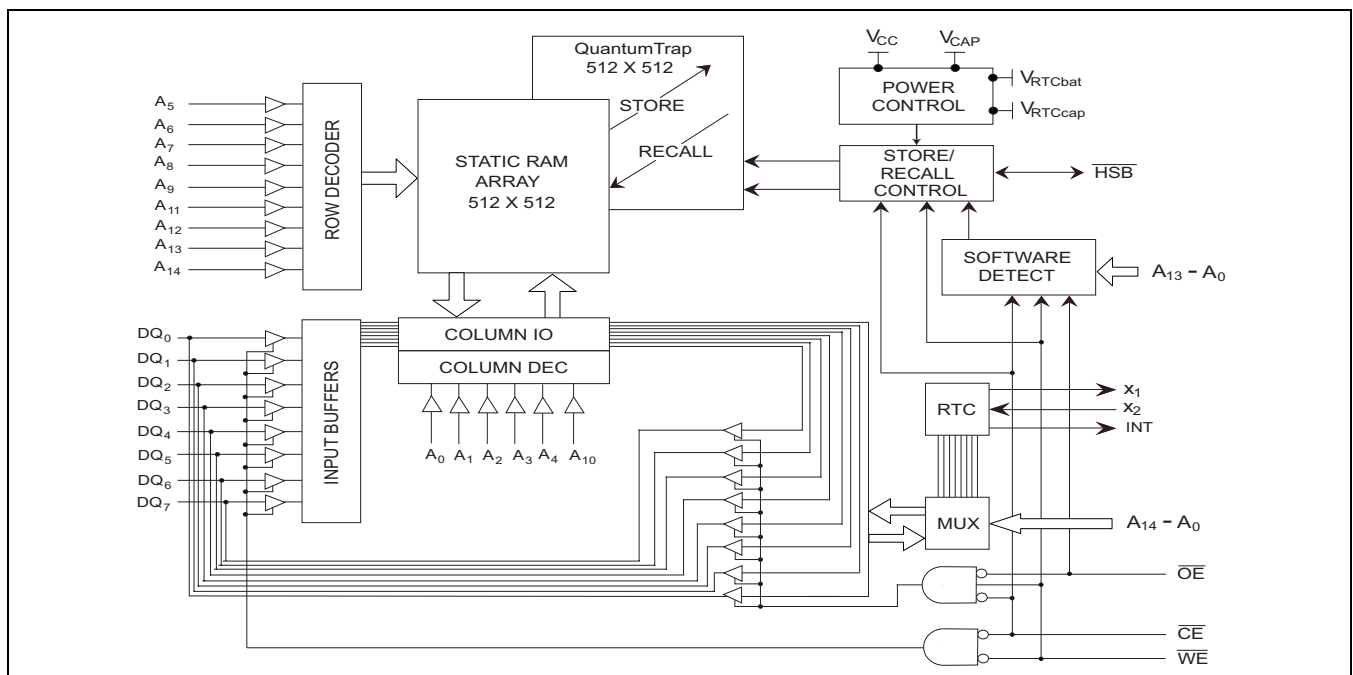

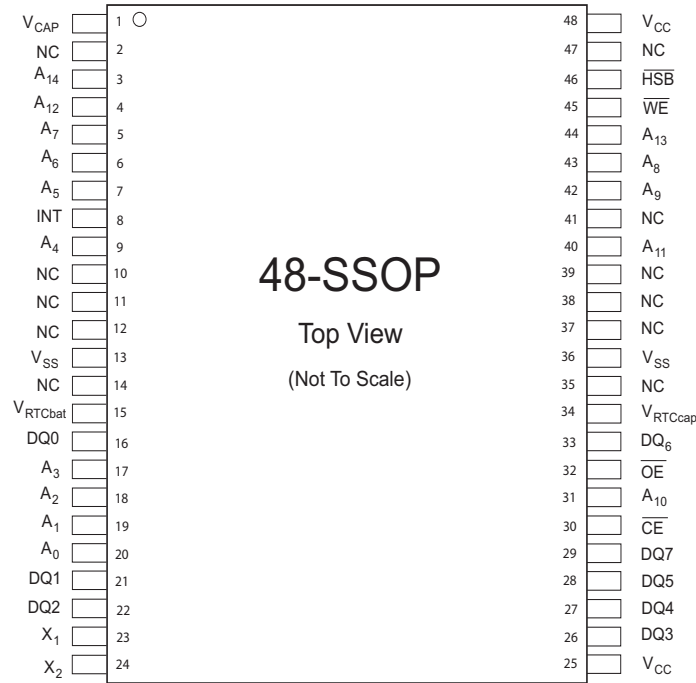
Pin Configurations

Pin Definitions

Pin Name	IO Type	Description
A ₀ –A ₁₄	Input	Address Inputs used to select one of the 32,768 bytes of the nvSRAM.
DQ0–DQ7	Input/Output	Bidirectional Data IO lines. Used as input or output lines depending on operation.
NC	No Connect	No Connects. This pin is not connected to the die.
WE	Input	Write Enable Input, active LOW. When selected <u>LOW</u> , enables data on the IO pins to be written to the address location latched by the falling edge of CE.
CE	Input	Chip Enable Input, active LOW. When <u>LOW</u> , selects the chip. When <u>HIGH</u> , deselects the chip.
OE	Input	Output Enable, active LOW. The active <u>LOW</u> OE input enables the data output buffers during read cycles. Deasserting OE high causes the IO pins to tri-state.
X ₁	Output	Crystal Connection, drives crystal on start-up.
X ₂	Input	Crystal Connection for 32.768-kHz crystal.
V _{RTCcap}	Power Supply	Capacitor-supplied backup RTC supply voltage. (Left unconnected if V _{RTCbat} is used)
V _{RTCbat}	Power Supply	Battery-supplied backup RTC supply voltage. (Left unconnected if V _{RTCcap} is used)
INT	Output	Interrupt Output. Can be programmed to respond to the clock alarm, the watchdog timer, and the power monitor. Programmable to either active <u>HIGH</u> (push/pull) or <u>LOW</u> (open-drain).
V _{SS}	Ground	Ground for the device. Must be connected to ground of the system.
V _{CC}	Power Supply	Power Supply inputs to the device.
HSB	Input/Output	Hardware Store Busy. When low this output indicates a Hardware Store is in progress. When pulled low external to the chip it will initiate a nonvolatile STORE operation. A weak internal pull-up resistor keeps this pin high if not connected. (Connection Optional)
V _{CAP}	Power Supply	AutoStore™ Capacitor. Supplies power to nvSRAM during power loss to store data from SRAM to nonvolatile elements.

Device Operation

The CY14B256K nvSRAM consists of two functional components paired in the same physical cell. The components are SRAM memory cell and a nonvolatile QuantumTrap cell. The SRAM memory cell operates as a standard fast static RAM. Data in the SRAM can be transferred to the nonvolatile cell (the STORE operation), or from the nonvolatile cell to SRAM (the RECALL operation). This architecture allows all cells to be stored and recalled in parallel. During the STORE and RECALL operations SRAM READ and WRITE operations are inhibited. The CY14B256K supports infinite reads and writes just like a typical SRAM. In addition, it provides infinite RECALL operations from the nonvolatile cells and up to 200,000 STORE operations.

SRAM Read

The CY14B256K performs a READ cycle whenever \overline{CE} and \overline{OE} are low while \overline{WE} and HSB are high. The address specified on pins A_{0-14} determines which of the 32,752 data bytes shall be accessed. When the READ is initiated by an address transition, the outputs will be valid after a delay of t_{AA} (READ cycle #1). If the READ is initiated by \overline{CE} or \overline{OE} , the outputs will be valid at t_{ACE} or at t_{DOE} , whichever is later (READ cycle #2). The data outputs will repeatedly respond to address changes within the t_{AA} access time without the need for transitions on any control input pins, and will remain valid until another address change or until \overline{CE} or \overline{OE} is brought high, or \overline{WE} or HSB is brought low.

SRAM Write

A WRITE cycle is performed whenever \overline{CE} and \overline{WE} are low and HSB is high. The address inputs must be stable prior to entering the WRITE cycle and must remain stable until either \overline{CE} or \overline{WE} goes high at the end of the cycle. The data on the common IO pins DQ_{0-7} be written into the memory if the data is valid t_{SD} before the end of a \overline{WE} controlled WRITE or before the end of an \overline{CE} controlled WRITE. \overline{OE} must be kept high during the entire WRITE cycle to avoid data bus contention on common IO lines. If \overline{OE} is left low, internal circuitry will turn off the output buffers t_{HZWE} after \overline{WE} goes low.

AutoStore Operation

The CY14B256K stores data to nvSRAM using one of three storage operations. The three storage operations are Hardware Store - activated by HSB, Software Store - activated by an address sequence, and AutoStore - on device power down. AutoStore operation is a unique feature of QuantumTrap technology and is enabled by default on the CY14B256K.

During normal operation, the device will draw current from V_{CC} to charge a capacitor connected to the V_{CAP} pin. This stored charge will be used by the chip to perform a single STORE operation. If the voltage on the V_{CC} pin drops below V_{SWITCH} , the part will automatically disconnect the V_{CAP} pin from V_{CC} . A STORE operation will be initiated with power provided by the V_{CAP} capacitor.

Figure 1 shows the proper connection of the storage capacitor. V_{CAP} for automatic store operation. Refer to the DC Electrical Characteristics on page 13 for the size of V_{CAP} . The voltage on the V_{CAP} pin is driven to 5V by a charge pump internal to

the chip. A pull up must be placed on \overline{WE} to hold it inactive during power up.

Figure 1. AutoStore™ Mode

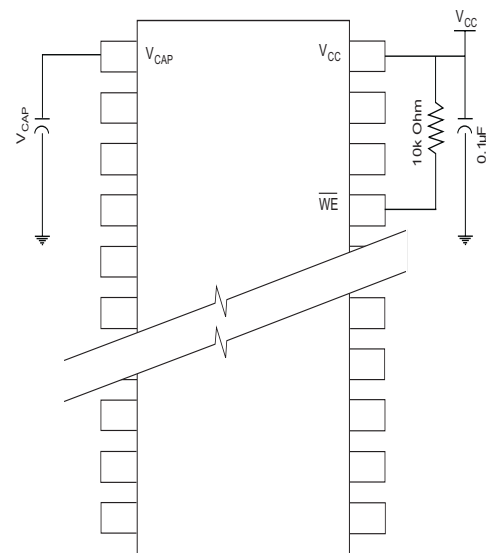

To reduce unnecessary nonvolatile stores, AutoStore and Hardware Store operations will be ignored unless at least one WRITE operation has taken place since the most recent STORE or RECALL cycle. Software initiated STORE cycles are performed regardless of whether a WRITE operation has taken place. The HSB signal can be monitored by the system to detect an AutoStore cycle is in progress.

Hardware STORE (HSB) Operation

The CY14B256K provides the \overline{HSB} pin for controlling and acknowledging the STORE operations. The \overline{HSB} pin can be used to request a hardware STORE cycle. When the \overline{HSB} pin is driven low, the CY14B256K will conditionally initiate a STORE operation after t_{DELAY} . An actual STORE cycle will only begin if a WRITE to the SRAM took place since the last STORE or RECALL cycle. The \overline{HSB} pin also acts as an open drain driver that is internally driven low to indicate a busy condition while the STORE (initiated by any means) is in progress.

SRAM READ and WRITE operations that are in progress when \overline{HSB} is driven low by any means are given time to complete before the STORE operation is initiated. After \overline{HSB} goes low, the CY14B256K will continue SRAM operations for t_{DELAY} . During t_{DELAY} , multiple SRAM READ operations may take place. If a WRITE is in progress when \overline{HSB} is pulled low it will be allowed a time, t_{DELAY} , to complete. However, any SRAM WRITE cycles requested after \overline{HSB} goes low will be inhibited until \overline{HSB} returns high.

During any STORE operation, regardless of how it was initiated, the CY14B256K will continue to drive the \overline{HSB} pin low, releasing it only when the STORE is complete. Upon completion of the STORE operation the CY14B256K will remain disabled until the \overline{HSB} pin returns high.

If \overline{HSB} is not used, it must be left unconnected.

Hardware RECALL (Power Up)

During power up, or after any low power condition ($V_{CC} < V_{SWITCH}$), an internal RECALL request will be latched. When V_{CC} once again exceeds the sense voltage of V_{SWITCH} , a RECALL cycle will be automatically initiated and will take $t_{HRECALL}$ to complete.

Software STORE

Data can be transferred from the SRAM to the nonvolatile memory by a software address sequence. The CY14B256K software STORE cycle is initiated by executing sequential \overline{CE} controlled READ cycles from six specific address locations in exact order. During the STORE cycle an erase of the previous nonvolatile data is first performed, followed by a program of the nonvolatile elements. Once a STORE cycle is initiated, further input and output are disabled until the cycle is completed.

Because a sequence of READs from specific addresses is used for STORE initiation, it is important that no other READ or WRITE accesses intervene in the sequence, or the sequence will be aborted and no STORE or RECALL will take place.

To initiate the software STORE cycle, the following READ sequence must be performed:

1. Read address 0x0E38, Valid READ
2. Read address 0x31C7, Valid READ
3. Read address 0x03E0, Valid READ
4. Read address 0x3C1F, Valid READ
5. Read address 0x303F, Valid READ
6. Read address 0x0FC0, Initiate STORE cycle

The software sequence may be clocked with \overline{CE} controlled READs or \overline{OE} controlled READs. Once the sixth address in the sequence has been entered, the STORE cycle will commence and the chip will be disabled. It is important that READ cycles

and not WRITE cycles be used in the sequence. It is not necessary that \overline{OE} be low for the sequence to be valid. After the t_{STORE} cycle time has been fulfilled, the SRAM will again be activated for READ and WRITE operation.

Software RECALL

Data can be transferred from the nonvolatile memory to the SRAM by a software address sequence. A software RECALL cycle is initiated with a sequence of READ operations in a manner similar to the software STORE initiation. To initiate the RECALL cycle, the following sequence of \overline{CE} controlled READ operations must be performed:

1. Read address 0x0E38, Valid READ
2. Read address 0x31C7, Valid READ
3. Read address 0x03E0, Valid READ
4. Read address 0x3C1F, Valid READ
5. Read address 0x303F, Valid READ
6. Read address 0x0C63, Initiate RECALL cycle

Internally, RECALL is a two step procedure. First, the SRAM data is cleared, and second, the nonvolatile information is transferred into the SRAM cells. After the t_{RECALL} cycle time the SRAM will once again be ready for READ and WRITE operations. The RECALL operation in no way alters the data in the nonvolatile elements.

Data Protection

The CY14B256K protects data from corruption during low voltage conditions by inhibiting all externally initiated STORE and WRITE operations. The low voltage condition is detected when $V_{CC} < V_{SWITCH}$. If the CY14B256K is in a WRITE mode (both \overline{CE} and \overline{WE} low) at power up, after a RECALL, or after a STORE, the \overline{WRITE} will be inhibited until a negative transition on \overline{CE} or \overline{WE} is detected. This protects against inadvertent writes during power up or brown out conditions.

Table 1. Mode Selection

\overline{CE}	\overline{WE}	\overline{OE}	A13–A0	Mode	IO	Power
H	X	X	X	Not Selected	Output High Z	Standby
L	H	L	X	Read SRAM	Output Data	Active
L	L	X	X	Write SRAM	Input Data	Active
L	H	L	0x0E38 0x31C7 0x03E0 0x3C1F 0x303F 0x0FC0	Read SRAM Read SRAM Read SRAM Read SRAM Read SRAM Nonvolatile Store	Output Data Output Data Output Data Output Data Output Data Output High Z	Active I_{CC2} [1, 2, 3]
L	H	L	0x0E38 0x31C7 0x03E0 0x3C1F 0x303F 0x0C63	Read SRAM Read SRAM Read SRAM Read SRAM Read SRAM Nonvolatile Recall	Output Data Output Data Output Data Output Data Output Data Output High Z	Active [1, 2, 3]

Notes:

1. The six consecutive address locations must be in the order listed. \overline{WE} must be HIGH during all six cycles to enable a nonvolatile cycle.
2. While there are 15 address lines on the CY14B256K, only the lower 14 lines are used to control software modes.
3. IO state depends on the state of \overline{OE} . The IO table shown is based on \overline{OE} Low.

Noise Considerations

The CY14B256K is a high-speed memory and so must have a high-frequency bypass capacitor of approximately 0.1 μF connected between V_{CC} and V_{SS} , using leads and traces that are as short as possible. As with all high speed CMOS ICs, careful routing of power, ground, and signals will reduce circuit noise.

Low Average Active Power

CMOS technology provides CY14B256K which allows drawing less current when it is cycled at times longer than 50 ns. Figure 2 shows the relationship between I_{CC} and READ and/or WRITE cycle time. Worst case current consumption is shown for commercial temperature range, $V_{CC} = 3.45\text{V}$, and chip enable at maximum frequency. Only standby current is drawn when the chip is disabled. The overall average current drawn by the CY14B256K depends on the following items:

1. The duty cycle of chip enable.
2. The overall cycle rate for accesses.
3. The ratio of READS to WRITES.
4. The operating temperature.
5. The V_{CC} level.
6. IO loading.

Figure 2. Current vs. Cycle Time

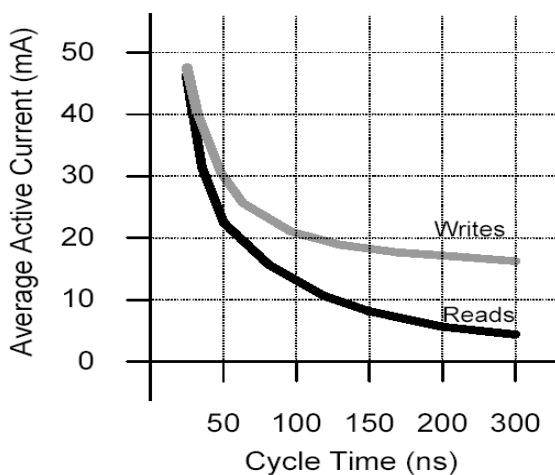

Real-Time-Clock Operation

nvTIME Operation

The CY14B256K consists of internal registers that contain clock, alarm, watchdog, interrupt, and control functions. Internal double buffering of the clock and the clock/timer information registers prevents accessing transitional internal clock data during a read or write operation. Double buffering also circumvents disrupting normal timing counts or clock accuracy of the internal clock while accessing clock data. Clock and Alarm Registers store data in BCD format.

Clock Operations

The clock registers maintain time up to 9,999 years in one second increments. The user can set the time to any calendar time and the clock automatically keeps track of days of the week and month, leap years, and century transitions. There are eight registers dedicated to the clock functions that are used to set time with a write cycle and to read time during a read cycle. These registers contain the time of day in BCD format. Bits defined as 0 are currently not used and are reserved for future use by Cypress.

Reading the Clock

While the double buffered RTC register structure reduces the chance of reading incorrect data from the clock, you to halt internal updates to the CY14B256K clock registers before reading clock data to prevent the reading of data in transition. Stopping the internal register updates does not affect clock accuracy. The update process is stopped by writing a 1 to the read bit R (in the flags register at 0x7FF0), and will not restart until a 0 is written to the read bit. The RTC registers can then be read while the internal clock continues to run. Within 20 ms after a 0 is written to the read bit, all CY14B256K registers are simultaneously updated.

Setting the Clock

Setting the write bit W (in the flags register at 0x7FF0) to a 1 stops updates to the CY14B256K registers. The correct day, date, and time can then be written into the registers in 24 hour BCD format. The time written is referred to as the Base Time. This value is stored in nonvolatile registers and used in calculation of the current time. Resetting the write bit to 0 transfers those values to the actual clock counters, after which the clock resumes normal operation.

Backup Power

The RTC in the CY14B256K is used for permanently powered operation. Either the V_{RTCcap} or V_{RTCbat} pin is connected depending on whether a capacitor or battery is chosen for the application. When primary power, V_{CC} , fails and drops below V_{SWITCH} the device will switch to the backup power supply.

The clock oscillator uses very little current, which maximizes the backup time available from the backup source. Regardless of clock operation with the primary source removed, the data stored in nvSRAM is secure, having been stored in the nonvolatile elements as power was lost.

During backup operation the CY14B256K consumes a maximum of 300 nA at 2V. Capacitor or battery values must be chosen according to the application. Backup time values based on maximum current specs are shown in Table 2, RTC Backup Time. Nominal times are approximately 3 times longer.

Table 2. RTC Backup Time

Capacitor Value	Backup Time
0.1F	72 hours
0.47F	14 days
1.0F	30 days

Using a capacitor has the advantage of recharging the backup source each time the system is powered up. If a battery is used, a 3V lithium is recommended and the CY14B256K will

only source current from the battery when the primary power is removed. The battery will not, however, be recharged at any time by the CY14B256K. The battery capacity must be chosen for total anticipated cumulative down time required over the life of the system.

Stopping and Starting the Oscillator

The **OSCEN** bit in calibration register at 0x7FF8 controls the starting and stopping of the oscillator. This bit is nonvolatile and shipped to customers in the enabled (set to 0) state. To preserve battery life while system is in storage **OSCEN** must be set to a 1. This will turn off the oscillator circuit, extending the battery life. If the **OSCEN** bit goes from disabled to enabled, it will take approximately take 5 seconds (10 seconds max) for the oscillator to start.

The CY14B256K has the ability to detect oscillator failure. This is recorded in the **OSCF** (Oscillator Failed bit) of the flags register at address 0x7FF0. When the device is powered on (V_{CC} goes above V_{SWITCH}) the **OSCEN** bit is checked for enabled status. If the **OSCEN** bit is enabled and the oscillator is not active, the **OSCF** bit is set. The user must check for this condition and then write a 0 to clear the flag. It must be noted that in addition to setting the **OSCF** flag bit, the time registers are reset to the Base Time (see the section [Setting the Clock on page 5](#)), which is the value last written to the timekeeping registers. The Control/Calibration register and the **OSCEN** bit are not affected by the oscillator failed condition.

If the voltage on the backup supply (either V_{RTCcap} or V_{RTCbat}) falls below its minimum level, the oscillator may fail, leading to the oscillator failed condition, which can be detected when system power is restored.

The value of **OSCF** must be reset to 0 when the time registers are written for the first time. This will initialize the state of this bit, which may have been set when the system was first powered on.

Calibrating the Clock

The RTC is driven by a quartz controlled oscillator with a nominal frequency of 32.768 kHz. Clock accuracy will depend on the quality of the crystal, usually specified to 35 ppm limits at 25°C. This error could equate to +1.53 minutes per month. The CY14B256K employs a calibration circuit that can improve the accuracy to +1/-2 ppm at 25°C. The calibration circuit adds or subtracts counts from the oscillator divider circuit.

The number of pulses that are suppressed (subtracted, negative calibration) or split (added, positive calibration) depends upon the value loaded into the five calibration bits found in calibration register at 0x7FF8. Adding counts speeds the clock up; subtracting counts slows the clock down. The calibration bits occupy the five lower order bits in the control register 8. These bits can be set to represent any value between 0 and 31 in binary form. Bit D5 is a sign bit, where a 1 indicates positive calibration and a 0 indicates negative calibration. Calibration occurs within a 64 minute cycle. The first 62 minutes in the cycle may, once per minute, have one second either shortened by 128 or lengthened by 256 oscillator cycles.

If a binary 1 is loaded into the register, only the first 2 minutes of the 64 minute cycle will be modified; if a binary 6 is loaded, the first 12 will be affected, and so on. Therefore each

calibration step has the effect of adding 512 or subtracting 256 oscillator cycles for every 125,829,120 actual oscillator cycles. That is 4.068 or -2.034 ppm of adjustment per calibration step in the calibration register.

In order to determine how to set the calibration one may set the **CAL** bit in the flags register at 0x7FF0 to 1, which causes the **INT** pin to toggle at a nominal 512 Hz. Any deviation measured from the 512 Hz will indicate the degree and direction of the required correction. For example, a reading of 512.010124 Hz would indicate a +20 ppm error, requiring a -10 (001010) to be loaded into the Calibration register. Note that setting or changing the calibration register does not affect the frequency test output frequency.

Alarm

The alarm function compares user programmed values to the corresponding time-of-day values. When a match occurs, the alarm event occurs. The alarm drives an internal flag, **AF**, and may drive the **INT** pin if desired.

There are four alarm match fields. They are date, hours, minutes, and seconds. Each of these fields also has a Match bit that is used to determine if the field is used in the alarm match logic. Setting the Match bit to 0 indicates that the corresponding field will be used in the match process.

Depending on the Match bits, the alarm can occur as specifically as one particular second on one day of the month, or as frequently as once per second continuously. The MSB of each alarm register is a Match bit. Selecting none of the Match bits (all 1s) indicates that no match is required. The alarm occurs every second. Setting the match select bit for seconds to 0 causes the logic to match the seconds alarm value to the current time of day. Since a match will occur for only one value per minute, the alarm occurs once per minute. Likewise, setting the seconds and minutes Match bits causes an exact match of these values. Thus, an alarm will occur once per hour. Setting seconds, minutes and hours causes a match once per day. Lastly, selecting all match values causes an exact time and date match. Selecting other bit combinations will not produce meaningful results; however the alarm circuit must follow the functions described.

There are two ways a user can detect an alarm event, by reading the **AF** flag or monitoring the **INT** pin. The **AF** flag in the flags register at 0x7FF0 will indicate that a date and time match has occurred. The **AF** bit will be set to 1 when a match occurs. Reading the Flags/Control register clears the alarm flag bit (and all others). A hardware interrupt pin may also be used to detect an alarm event.

Watchdog Timer

The watchdog timer is a free running down counter that uses the 32 Hz clock (31.25 ms) derived from the crystal oscillator. The oscillator must be running for the watchdog to function. It begins counting down from the value loaded in the Watchdog Timer register.

The counter consists of a loadable register and a free running counter. On power up, the watchdog time out value in register 0x7FF7 is loaded into the counter load register. Counting begins on power up and restarts from the loadable value any time the Watchdog Strobe (**WDS**) bit is set to 1. The counter is compared to the terminal value of 0. If the counter reaches this value, it causes an internal flag and an optional interrupt

output. You can prevent the time out interrupt by setting WDS bit to 1 prior to the counter reaching 0. This causes the counter to be reloaded with the watchdog time out value and to be restarted. As long as the user sets the WDS bit prior to the counter reaching the terminal value, the interrupt and flag never occurs.

New time out values can be written by setting the watchdog write bit to 0. When the WDW is 0 (from the previous operation), new writes to the watchdog time out value bits D5-D0 allow the time out value to be modified. When WDW is a 1, writes to bits D5-D0 will be ignored. The WDW function allows a user to set the WDS bit without concern that the watchdog timer value will be modified. A logical diagram of the watchdog timer is shown in Figure 3. Note that setting the watchdog time out value to 0 would be otherwise meaningless and therefore disables the watchdog function.

The output of the watchdog timer is a flag bit WDF that is set if the watchdog is allowed to time out. The flag is set upon a watchdog time out and cleared when the Flags/Control register is read by the user. The user can also enable an optional interrupt source to drive the INT pin if the watchdog time out occurs.

Figure 3. Watchdog Timer Block Diagram

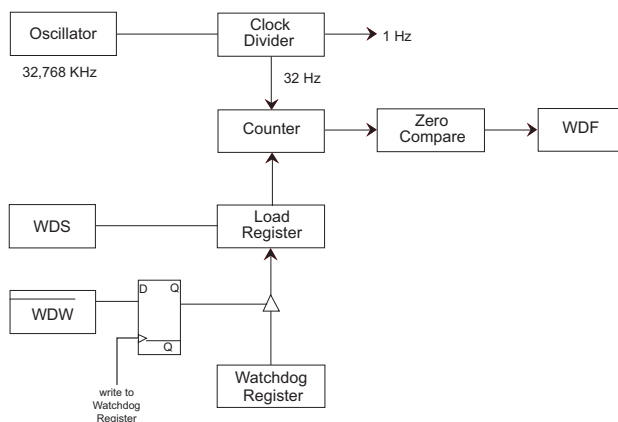

Power Monitor

The CY14B256K provides a power management scheme with power fail interrupt capability. It also controls the internal switch to backup power for the clock and protects the memory from low V_{CC} access. The power monitor is based on an internal band gap reference circuit that compares the V_{CC} voltage to various thresholds.

As described in the [AutoStore Operation on page 3](#), when V_{SWITCH} is reached as V_{CC} decays from power loss, a data store operation is initiated from SRAM to the nonvolatile elements, securing the last SRAM data state. Power is also switched from V_{CC} to the backup supply (battery or capacitor) to operate the RTC oscillator.

When operating from the backup source, no data may be read or written and the clock functions are not available to the user. The clock continues to operate in the background. Updated clock data is available to the user after V_{CC} has been restored

to the device and tHRECALL delay (see [AutoStore/Power Up RECALL on page 16](#)).

Interrupts

The CY14B256K provides three potential interrupt sources. They include the watchdog timer, the power monitor, and the clock/calendar alarm. Each can be individually enabled and assigned to drive the INT pin. In addition, each has an associated flag bit that the host processor can use to determine the cause of the interrupt. Some of the sources have additional control bits that determine functional behavior. In addition, the pin driver has three bits that specify its behavior when an interrupt occurs.

The three interrupts each have a source and an enable. Both the source and the enable must be active (true high) in order to generate an interrupt output. Only one source is necessary to drive the pin. The user can identify the source by reading the Flags/Control register, which contains the flags associated with each source. All flags are cleared to 0 when the register is read. The flags will be cleared only after a complete read cycle (WE high); The power monitor has two programmable settings that are explained in the power monitor section.

Once an interrupt source is active, the pin driver determines the behavior of the output. It has two programmable settings as shown in the following sections. Pin driver control bits are located in the interrupts register.

According to the programming selections, the pin can be driven in the backup mode for an alarm interrupt. In addition, the pin can be an active LOW (open-drain) or an active HIGH (push-pull) driver. If programmed for operation during backup mode, it can only be active LOW. Lastly, the pin can provide a one shot function so that the active condition is a pulse or a level condition. In one shot mode, the pulse width is internally fixed at approximately 200 ms. This mode is intended to reset a host microcontroller. In level mode, the pin goes to its active polarity until the Flags/Control register is read by the user. This mode is intended to be used as an interrupt to a host microcontroller. The Interrupt register is initialized to 00h. The control bits are summarized as follows:

Watchdog Interrupt Enable - WIE. When set to 1, the watchdog timer drives the INT pin as well as an internal flag when a watchdog time out occurs. When WIE is set to 0, the watchdog timer affects only the internal flag.

Alarm Interrupt Enable - AIE. When set to 1, the alarm match drives the INT pin as well as an internal flag. When set to 0, the alarm match only affects to internal flag.

Power Fail Interrupt Enable - PFE. When set to 1, the power fail monitor drives the pin as well as an internal flag. When set to 0, the power fail monitor affects only the internal flag.

High/Low - H/L. When set to a 1, the INT pin is active HIGH and the driver mode is push pull. The INT pin can drive high only when V_{CC} > V_{SWITCH}. When set to a 0, the INT pin is active LOW and the drive mode is opendrain. Active LOW (open drain) is operational even in battery backup mode.

Pulse/Level - P/L. When set to a 1 and an interrupt occurs, the INT pin is driven for approximately 200 ms. When P/L is set to a 0, the INT pin is driven high or low (determined by H/L) until the Flags/Control register is read.

When an enabled interrupt source activates the INT pin, an external host can read the Flags/Control register to determine

the cause. Remember that all flags will be cleared when the register is read. If the INT pin is programmed for Level mode, then the condition will clear and the INT pin will return to its inactive state. If the pin is programmed for Pulse mode, then reading the flag also will clear the flag and the pin. The pulse will not complete its specified duration if the Flags/Control register is read. If the INT pin is used as a host reset, then the Flags/Control register must not be read during a reset.

During a power on reset with no battery, the interrupt register is automatically loaded with the value 24h. This causes power fail interrupt to be enabled with an active low pulse.

Flags Register - The Flags register has three flag bits: WDF, AF, and PF. These flag bits are initialized to 00h. These flags are set by the watchdog time out, alarm match, or power fail monitor respectively. The processor can either poll this register or enable interrupts to be informed when a flag is set. The flags are automatically reset once the register is read.

Figure 4. RTC Recommended Component Configuration

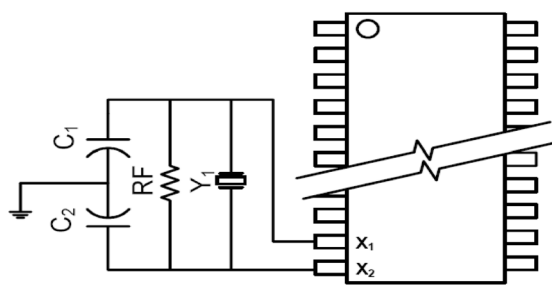
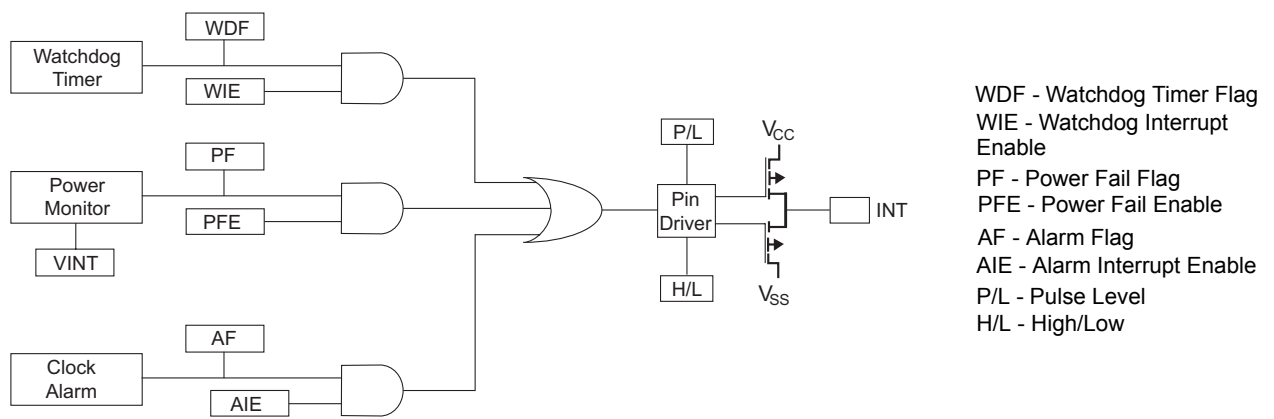

Recommended Values

- Y1 = 32.768KHz
- RF = 10M Ohm
- C1 = 0
- C2 = 56 pF

Table 3. RTC Register Map

Register	BCD Format Data								Function/Range
	D7	D6	D5	D4	D3	D2	D1	D0	
0x7FFF	10s Years				Years				Years: 00–99
0x7FFE	0	0	0	10s Months	Months				Months: 01–12
0x7FFD	0	0	10s Day of Month		Day Of Month				Day of Month: 01–31
0x7FFC	0	0	0	0	0	Day of week			Day of week: 01–07
0x7FFB	0	0	10s Hours		Hours				Hours: 00–23
0x7FFA	0	10s Minutes			Minutes				Minutes: 00–59
0x7FF9	10s Seconds			Seconds				Seconds: 00–59	
0x7FF8	OSCEN	0	Cal Sign	Calibration				Calibration Values ^[4]	
0x7FF7	WDS	WDW	WDT				Watchdog ^[4]		
0x7FF6	WIE	AIE	PFE	0	H/L	P/L	0	0	Interrupts ^[4]
0x7FF5	M	0	10s Alarm Date		Alarm Day				Alarm, Day of Month: 01–31
0x7FF4	M	0	10s Alarm Hours		Alarm Hours				Alarm, Hours: 00–23
0x7FF3	M	10 Alarm Minutes			Alarm Minutes				Alarm, Minutes: 00–59
0x7FF2	M	10 Alarm Minutes			Alarm, Seconds				Alarm, Seconds: 00–59
0x7FF1	10s Centuries			Centuries				Centuries: 00–99	
0x7FF0	WDF	AF	PF	OSCF	0	CAL	W	R	Flags ^[4]

Table 4. Register Map Detail

0x7FFF	Time Keeping - Years							
	D7	D6	D5	D4	D3	D2	D1	D0
	10s Years				Years			
	Contains the lower two BCD digits of the year. Lower nibble contains the value for years; upper nibble contains the value for 10s of years. Each nibble operates from 0 to 9. The range for the register is 0–99.							
0x7FFE	Time Keeping - Months							
	D7	D6	D5	D4	D3	D2	D1	D0
	0	0	0	10s Month	Months			
	Contains the BCD digits of the month. Lower nibble contains the lower digit and operates from 0 to 9; upper nibble (one bit) contains the upper digit and operates from 0 to 1. The range for the register is 1–12.							
0x7FFD	Time Keeping - Date							
	D7	D6	D5	D4	D3	D2	D1	D0
	0	0	10s Day of Month		Day of Month			
	Contains the BCD digits for the date of the month. Lower nibble contains the lower digit and operates from 0 to 9; upper nibble contains the upper digit and operates from 0 to 3. The range for the register is 1–31. Leap years are automatically adjusted for.							
0x7FFC	Time Keeping - Day							
	D7	D6	D5	D4	D3	D2	D1	D0
	0	0	0	0	0	Day of Week		
	Lower nibble contains a value that correlates to day of the week. Day of the week is a ring counter that counts from 1 to 7 then returns to 1. The user must assign meaning to the day value, as the day is not integrated with the date.							

Note:

4. Is a binary value, not a BCD value.

Table 4. Register Map Detail (continued)

0x7FFB	Time Keeping - Hours							
	D7	D6	D5	D4	D3	D2	D1	D0
	12/24	0	10s Hours			Hours		
	Contains the BCD value of hours in 24 hour format. Lower nibble contains the lower digit and operates from 0 to 9; upper nibble (two bits) contains the upper digit and operates from 0 to 2. The range for the register is 0–23.							
0x7FFA	Time Keeping - Minutes							
	D7	D6	D5	D4	D3	D2	D1	D0
	0	10s Minutes			Minutes			
	Contains the BCD value of minutes. Lower nibble contains the lower digit and operates from 0 to 9; upper nibble contains the upper minutes digit and operates from 0 to 5. The range for the register is 0–59.							
0x7FF9	Time Keeping - Seconds							
	D7	D6	D5	D4	D3	D2	D1	D0
	0	10s Seconds			Seconds			
	Contains the BCD value of seconds. Lower nibble contains the lower digit and operates from 0 to 9; upper nibble contains the upper digit and operates from 0 to 5. The range for the register is 0–59.							
0x7FF8	Calibration/Control							
	D7	D6	D5	D4	D3	D2	D1	D0
	OSCEN	0	Calibration Sign	Calibration				
	OSCEN	Oscillator Enable. When set to 1, the oscillator is halted. When set to 0, the oscillator runs. Disabling the oscillator saves battery/capacitor power during storage. On a no-battery power up, this bit is set to 0.						
Calibration Sign	Determines if the calibration adjustment is applied as an addition to or as a subtraction from the time-base.							
Calibration	These five bits control the calibration of the clock.							
0x7FF7	WatchDog Timer							
	D7	D6	D5	D4	D3	D2	D1	D0
	WDS	WDW	WDT					
	WDS	Watchdog Strobe. Setting this bit to 1 reloads and restarts the watchdog timer. Setting the bit to 0 has no affect. The bit is cleared automatically once the watchdog timer is reset. The WDS bit is write only. Reading it always will return a 0.						
WDW	Watchdog Write Enable. Setting this bit to 1 masks the watchdog time-out value (WDT5–WDT0) so it cannot be written. This allows the user to strobe the watchdog without disturbing the time-out value. Setting this bit to 0 allows bits 5–0 to be written on the next write to the Watchdog register. The new value will be loaded on the next internal watchdog clock after the write cycle is complete. This function is explained in more detail in the watchdog timer section.							
WDT	Watchdog time-out selection. The watchdog timer interval is selected by the 6-bit value in this register. It represents a multiplier of the 32-Hz count (31.25 ms). The minimum range or time-out value is 31.25 ms (a setting of 1) and the maximum time-out is 2 seconds (setting of 3Fh). Setting the watchdog timer register to 0 disables the timer. These bits can be written only if the WDW bit was cleared to 0 on a previous cycle.							

Table 4. Register Map Detail (continued)

		Interrupt Status/Control							
		D7	D6	D5	D4	D3	D2	D1	D0
0x7FF6		WIE	AIE	PFIE	0	H/L	P/L	0	0
WIE	Watchdog Interrupt Enable. When set to 1 and a watchdog time-out occurs, the watchdog timer drives the INT pin as well as the WDF flag. When set to 0, the watchdog time-out affects only the WDF flag.								
AIE	Alarm Interrupt Enable. When set to 1, the alarm match drives the INT pin as well as the AF flag. When set to 0, the alarm match only affects the AF flag.								
PFIE	Power Fail Enable. When set to 1, the alarm match drives the INT pin as well as the PF flag. When set to 0, the power fail monitor affects only the PF flag.								
H/L	High/Low. When set to a 1, the INT pin is driven active HIGH. When set to 0, the INT pin is open drain, active LOW.								
P/L	Pulse/Level. When set to a 1, the INT pin is driven active (determined by H/L) by an interrupt source for approximately 200 ms. When set to a 0, the INT pin is driven to an active level (as set by H/L) until the Flags/Control register is read.								
		Alarm - Day							
		D7	D6	D5	D4	D3	D2	D1	D0
0x7FF5		M	0	10s Alarm Date			Alarm Date		
M	Contains the alarm value for the date of the month and the mask bit to select or deselect the date value.								
M	Match. Setting this bit to 0 causes the date value to be used in the alarm match. Setting this bit to 1 causes the match circuit to ignore the date value.								
		Alarm - Hours							
		D7	D6	D5	D4	D3	D2	D1	D0
0x7FF4		M	0	10s Alarm Hours			Alarm Hours		
M	Contains the alarm value for the hours and the mask bit to select or deselect the hours value.								
M	Match. Setting this bit to 0 causes the hours value to be used in the alarm match. Setting this bit to 1 causes the match circuit to ignore the hours value.								
		Alarm - Minutes							
		D7	D6	D5	D4	D3	D2	D1	D0
0x7FF3		M	0	10s Alarm Minutes			Alarm Minutes		
M	Contains the alarm value for the minutes and the mask bit to select or deselect the minutes value.								
M	Match. Setting this bit to 0 causes the minutes value to be used in the alarm match. Setting this bit to 1 causes the match circuit to ignore the minutes value.								
		Alarm - Seconds							
		D7	D6	D5	D4	D3	D2	D1	D0
0x7FF2		M	0	10s Alarm Seconds			Alarm Seconds		
M	Contains the alarm value for the seconds and the mask bit to select or deselect the seconds' value.								
M	Match. Setting this bit to 0 causes the seconds' value to be used in the alarm match. Setting this bit to 1 causes the match circuit to ignore the seconds value.								
		Time Keeping - Centuries							
		D7	D6	D5	D4	D3	D2	D1	D0
0x7FF1		0	0	10s Centuries			Centuries		

Table 4. Register Map Detail (continued)

0x7FF0	Flags							
	D7	D6	D5	D4	D3	D2	D1	D0
	WDF	AF	PF	OSCF	0	CAL	W	R
WDF	Watchdog Timer Flag. This read-only bit is set to 1 when the watchdog timer is allowed to reach 0 without being reset by the user. It is cleared to 0 when the Flags/Control register is read.							
AF	Alarm Flag. This read-only bit is set to 1 when the time and date match the values stored in the alarm registers with the match bits = 0. It is cleared when the Flags/Control register is read.							
PF	Power-fail Flag. This read-only bit is set to 1 when power falls below the power-fail threshold V_{SWITCH} . It is cleared to 0 when the Flags/Control register is read.							
OSCF	Oscillator Fail Flag. Set to 1 on power up only if the oscillator is not running in the first 5 ms of power on operation. This indicates that time counts are no longer valid. The user must reset this bit to 0 to clear this condition. The chip will not clear this flag. This bit survives power cycles.							
CAL	Calibration Mode. When set to 1, a 512-Hz square wave is output on the INT pin. When set to 0, the INT pin resumes normal operation. This bit defaults to 0 (disabled) on power up.							
W	Write Time. Setting the W bit to 1 freeze updates of the timekeeping registers. The user can then write them with updated values. Setting the W bit to 0 causes the contents of the time registers to be transferred to the timekeeping counters. The W-bit enables writes to RTC, Alarm, Calibration, Interrupt, and Flag registers.							
R	Read Time. Setting the R bit to 1 copies a static image of the timekeeping registers and places them in a holding register. The user can then read them without concerns over changing values causing system errors. The R bit going from 0 to 1 causes the timekeeping capture, so the bit must be returned to 0 prior to reading again.							

Maximum Ratings

Exceeding maximum ratings may impair the useful life of the device. For user guidelines, not tested.

- Storage Temperature -65°C to +150°C
- Ambient Temperature with Power Applied -55°C to +125°C
- Supply Voltage on V_{CC} Relative to GND -0.5V to 4.1V
- Voltage Applied to Outputs in High-Z State -0.5V to V_{CC} + 0.5V
- Input Voltage -0.5V to V_{CC}+0.5V
- Transient Voltage (<20 ns) on Any Pin to Ground Potential -2.0V to V_{CC} + 2.0V

- Package Power Dissipation Capability (T_A = 25°C) 1.0W
- Surface Mount Pb Soldering Temperature (3 Seconds) +260°C
- Output Short Circuit Current [5] 15 mA
- Static Discharge Voltage > 2001V (per MIL-STD-883, Method 3015)
- Latch-up Current > 200 mA

Operating Range

Range	Ambient Temperature	V _{CC}
Commercial	0°C to +70°C	2.7V to 3.45V
Industrial	-40°C to +85°C	2.7V to 3.45V

DC Electrical Characteristics

Over the Operating Range (V_{CC} = 2.7V to 3.45V) [6, 7, 8]

Parameter	Description	Test Conditions	Min	Max	Unit
I _{CC1}	Average V _{CC} Current	t _{RC} = 25 ns t _{RC} = 35 ns t _{RC} = 45 ns Dependent on output loading and cycle rate. Values obtained without output loads. I _{OUT} = 0mA.	Commercial	65 55 50	mA mA mA
			Industrial	55 (t _{RC} = 45 ns)	mA mA mA
I _{CC2}	Average V _{CC} Current during STORE	All Inputs Don't Care, V _{CC} = Max Average current for duration t _{STORE}		3	mA
I _{CC3}	Average V _{CC} Current at t _{AVAV} = 200 ns, 3V, 25°C typical	$\overline{WE} > (V_{CC} - 0.2)$. All other inputs cycling. Dependent on output loading and cycle rate. Values obtained without output loads.		10	mA
I _{CC4}	Average V _{CAP} Current during AutoStore Cycle	All Inputs Don't Care, V _{CC} = Max Average current for duration t _{STORE}		3	mA
I _{SB}	V _{CC} Standby Current	$\overline{WE} > (V_{CC} - 0.2)$. All others V _{IN} < 0.2V or > (V _{CC} - 0.2V). Standby current level after nonvolatile cycle is complete. Inputs are static. f = 0MHz.		3	mA
I _{IX}	Input Leakage Current	V _{CC} = Max, V _{SS} ≤ V _{IN} ≤ V _{CC}	-1	+1	µA
I _{OZ}	Off-State Output Leakage Current	V _{CC} = Max, V _{SS} ≤ V _{IN} ≤ V _{CC} , CE or OE > V _{IH}	-1	+1	µA
V _{IH}	Input HIGH Voltage		2.0	V _{CC} + 0.3	V
V _{IL}	Input LOW Voltage		V _{SS} - 0.5	0.8	V
V _{OH}	Output HIGH Voltage	I _{OUT} = -2 mA	2.4		V
V _{OL}	Output LOW Voltage	I _{OUT} = 4 mA		0.4	V
V _{CAP}	Storage Capacitor	Between V _{CAP} pin and V _{SS} , 5V Rated	17	120	µF

Notes:

5. Outputs shorted for no more than one second. No more than one output shorted at a time.
6. Typical conditions for the Active Current shown on the front page of the data sheet are average values at 25°C (room temperature), and V_{CC} = 3V. Not 100% tested.
7. The HSB pin has I_{OUT} = -10 µA for V_{OH} of 2.4 V, this parameter is characterized but not tested.
8. The INT pin is open-drain and does not source or sink current when Interrupt Register bit D3 is low.

Capacitance [9]

Parameter	Description	Test Conditions	Max	Unit
C _{IN}	Input Capacitance	T _A = 25°C, f = 1 MHz, V _{CC} = 0 to 3.0 V	7	pF
C _{OUT}	Output Capacitance		7	pF

Thermal Resistance [9]

Parameter	Description	Test Conditions	48-SSOP	Unit
Θ _{JA}	Thermal Resistance (Junction to Ambient)	Test conditions follow standard test methods and procedures for measuring thermal impedance, in accordance with EIA / JESD51.	TBD	°C/W
Θ _{JC}	Thermal Resistance (Junction to Case)		TBD	°C/W

AC Test Loads

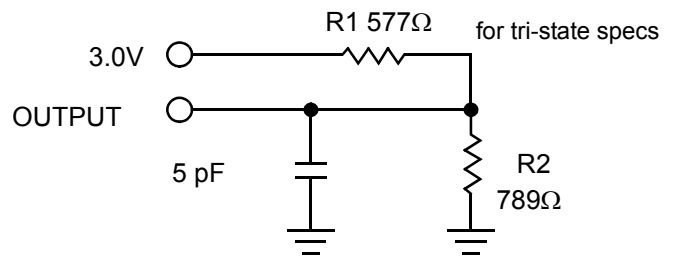
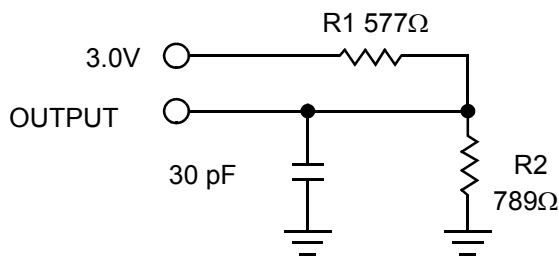

AC Test Conditions

Input Pulse Levels..... 0 V to 3 V
 Input Rise and Fall Times (10% - 90%) ≤5 ns
 Input and Output Timing Reference Levels..... 1.5 V

Note:
 9. These parameters are guaranteed but not tested.

AC Switching Characteristics

Parameter		Description	25ns part		35ns part		45ns part		Unit
Cypress Parameter	Alt. Parameter		Min	Max	Min	Max	Min	Max	
SRAM Read Cycle									
t _{ACE}	t _{ACS}	Chip Enable Access Time		25		35		45	ns
t _{RC} ^[10]	t _{RC}	Read Cycle Time	25		35		45		ns
t _{AA} ^[11]	t _{AA}	Address Access Time		25		35		45	ns
t _{DOE}	t _{OE}	Output Enable to Data Valid		12		15		20	ns
t _{OHA} ^[11]	t _{OH}	Output Hold After Address Change	3		3		3		ns
t _{LZCE} ^[12]	t _{LZ}	Chip Enable to Output Active	3		3		3		ns
t _{HZCE} ^[12]	t _{HZ}	Chip Disable to Output Inactive		10		13		15	ns
t _{LZOE} ^[12]	t _{OLZ}	Output Enable to Output Active	0		0		0		ns
t _{HZOE} ^[12]	t _{OHZ}	Output Disable to Output Inactive		10		13		15	ns
t _{PU} ^[9]	t _{PA}	Chip Enable to Power Active	0		0		0		ns
t _{PD} ^[9]	t _{PS}	Chip Disable to Power Standby		25		35		45	ns
SRAM Write Cycle									
t _{WC}	t _{WC}	Write Cycle Time	25		35		45		ns
t _{PWE}	t _{WP}	Write Pulse Width	20		25		30		ns
t _{SCE}	t _{CW}	Chip Enable To End of Write	20		25		30		ns
t _{SD}	t _{DW}	Data Set-Up to End of Write	10		12		15		ns
t _{HD}	t _{DH}	Data Hold After End of Write	0		0		0		ns
t _{AW}	t _{AW}	Address Set-Up to End of Write	20		25		30		ns
t _{SA}	t _{AS}	Address Set-Up to Start of Write	0		0		0		ns
t _{HA}	t _{WR}	Address Hold After End of Write	0		0		0		ns
t _{HZWE} ^[12, 13]	t _{WZ}	Write Enable to Output Disable		10		13		15	ns
t _{LZWE} ^[12]	t _{OW}	Output Active after End of Write	3		3		3		ns

Notes:

- 10. WE must be HIGH during SRAM Read Cycles.
- 11. Device is continuously selected with CE and OE both Low.
- 12. Measured ±200 mV from steady state output voltage.
- 13. If WE is Low when CE goes Low, the outputs remain in the High Impedance State.

AutoStore/Power Up RECALL

Parameter	Description	CY14B256K		Unit
		Min	Max	
t _{HRECALL} [14]	Power Up RECALL Duration		20	ms
t _{STORE} [15, 16]	STORE Cycle Duration		12.5	ms
V _{SWITCH}	Low Voltage Trigger Level		2.65	V
t _{VCCRISE}	VCC Rise Time	150		μs

Software Controlled STORE/RECALL Cycle [17, 18]

Parameter	Description	25ns part		35ns part		45ns part		Unit
		Min	Max	Min	Max	Min	Max	
t _{RC}	STORE/RECALL Initiation Cycle Time	25		35		45		ns
t _{AS}	Address Set-Up Time	0		0		0		ns
t _{CW}	Clock Pulse Width	20		25		30		ns
t _{GHAX}	Address Hold Time	1		1		1		ns
t _{RECALL}	RECALL Duration		100		100		100	μs
t _{SS} [19, 20]	Soft Sequence Processing Time		70		70		70	μs

Hardware STORE Cycle

Parameter	Description	CY14B256K		Unit
		Min	Max	
t _{DELAY} [21]	Time allowed to complete SRAM Cycle	1	70	μs
t _{HLHX}	Hardware STORE Pulse Width	15		ns

RTC Characteristics

Parameter	Description	Test Conditions		Min	Max	Unit
I _{BAK} [22]	RTC Backup Current		Commercial		300	nA
			Industrial		350	nA
V _{RTCbat} [23]	RTC Battery Pin Voltage		Commercial	1.8	3.3	V
			Industrial	1.8	3.3	V
V _{RTCcap} [24]	RTC Capacitor Pin Voltage		Commercial	1.2	2.7	V
			Industrial	1.2	2.7	V
t _{OCS}	RTC Oscillator Time to Start	@Min. Temperature from Power up or Enable	Commercial		10	sec
		@25°C Temperature from Power up or Enable	Commercial		5	sec
		@Min. Temperature from Power up or Enable	Industrial		10	sec
		@25°C Temperature from Power up or Enable	Industrial		5	sec

Notes:

- 14. t_{HRECALL} starts from the time V_{CC} rises above V_{SWITCH}.
- 15. If an SRAM Write has not taken place since the last nonvolatile cycle, no STORE will take place.
- 16. Industrial Grade Devices require 15 ms Max
- 17. The software sequence is clocked with \overline{CE} -controlled or \overline{OE} -controlled READS.
- 18. The six consecutive addresses must be read in the order listed in the Mode Selection table. \overline{WE} must be HIGH during all six consecutive cycles.
- 19. This is the amount of time it takes to take action on a soft sequence command. V_{cc} power must remain HIGH to effectively register command.
- 20. Commands like STORE and RECALL lock out IO until operation is complete which further increases this time. See specific command.
- 21. Read and Write cycles in progress before \overline{HSB} are given this amount of time to complete.
- 22. From either V_{RTCcap} or V_{RTCbat}.
- 23. Typical = 3.0V during normal operation.
- 24. Typical = 2.4V during normal operation.

Switching Waveforms

Figure 5. SRAM Read Cycle #1: Address Controlled [10, 11, 25]

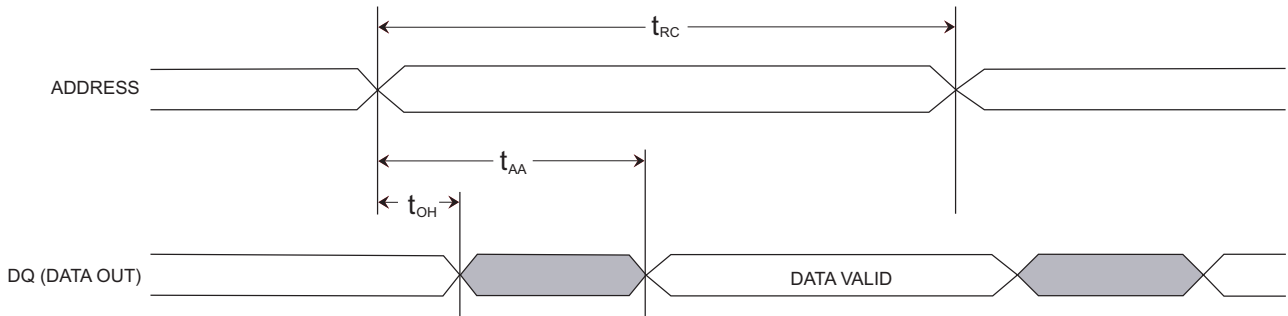
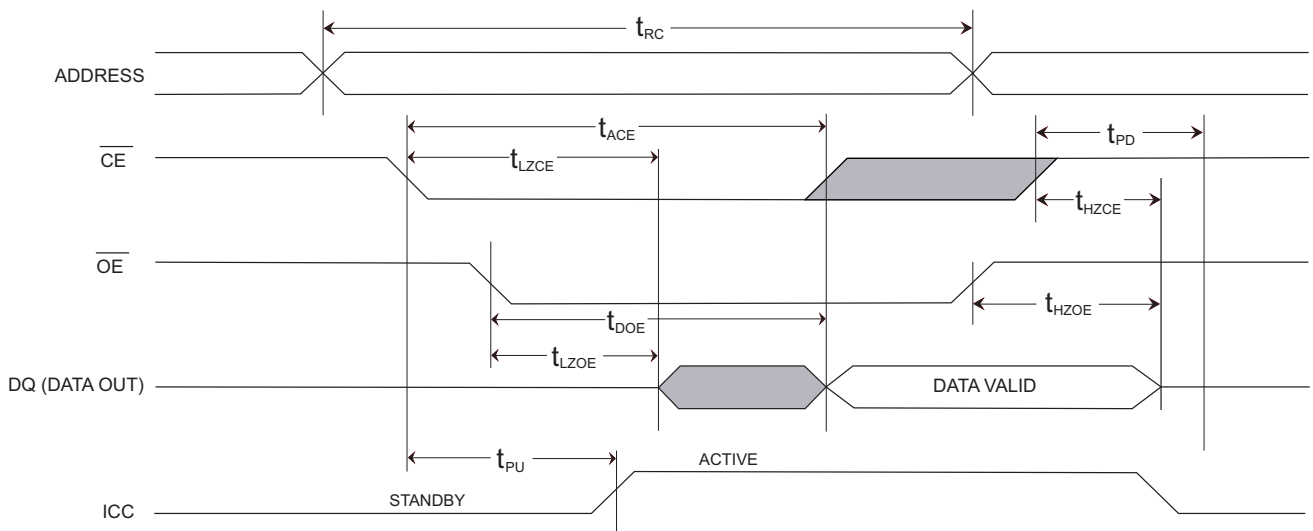

Figure 6. SRAM Read Cycle #2: \overline{CE} and \overline{OE} Controlled [10, 25]



Note:
25. HSB must remain HIGH during READ and WRITE cycles.

Switching Waveforms (continued)

Figure 7. SRAM Write Cycle #1: \overline{WE} Controlled [25, 26]

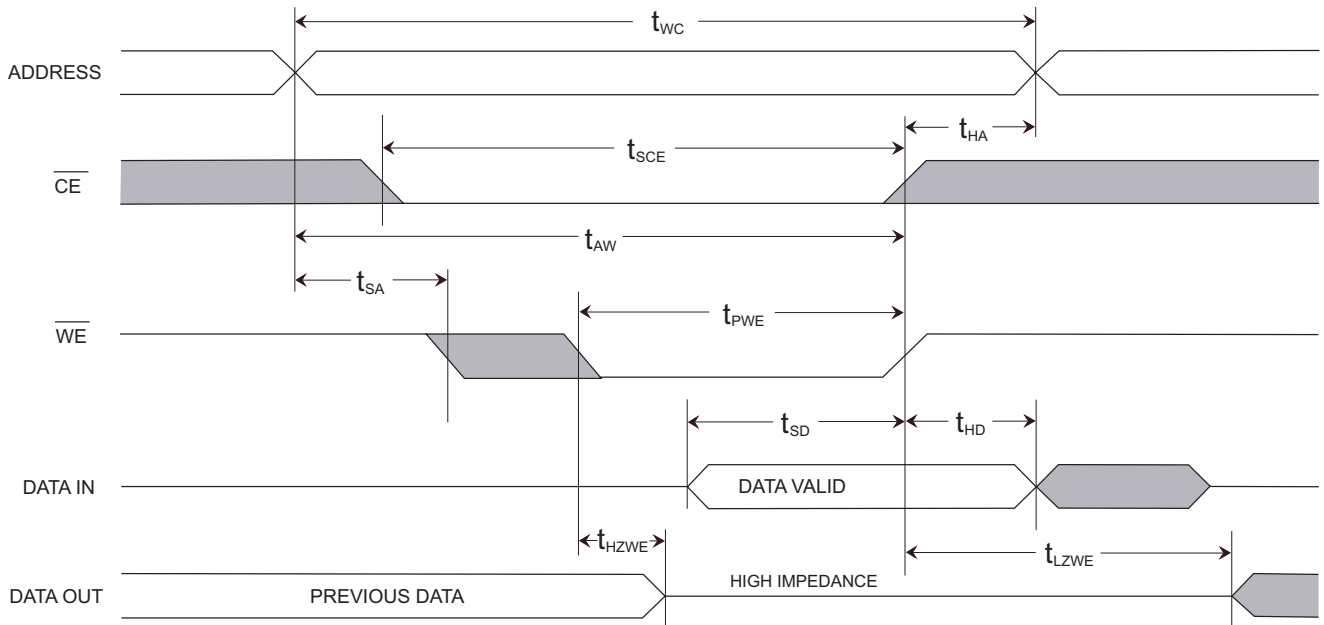
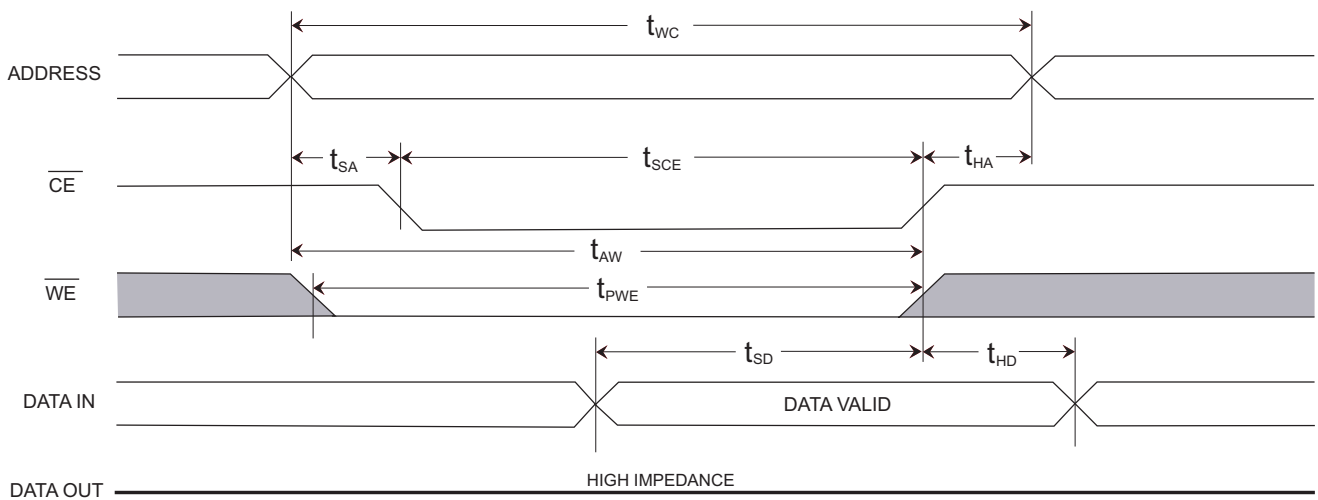

Figure 8. SRAM Write Cycle #2: \overline{CE} Controlled



Note:
26. \overline{CE} or \overline{WE} must be $> V_{IH}$ during address transitions.

Switching Waveforms (continued)

Figure 9. AutoStore/Power Up RECALL

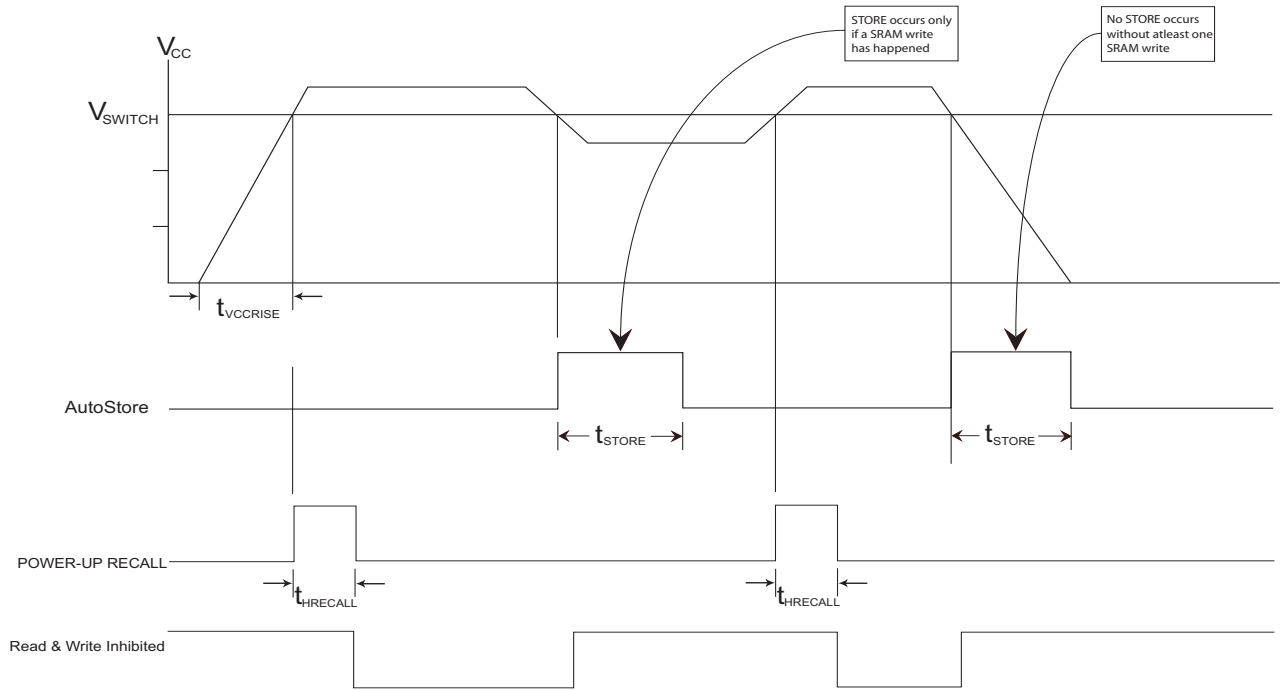
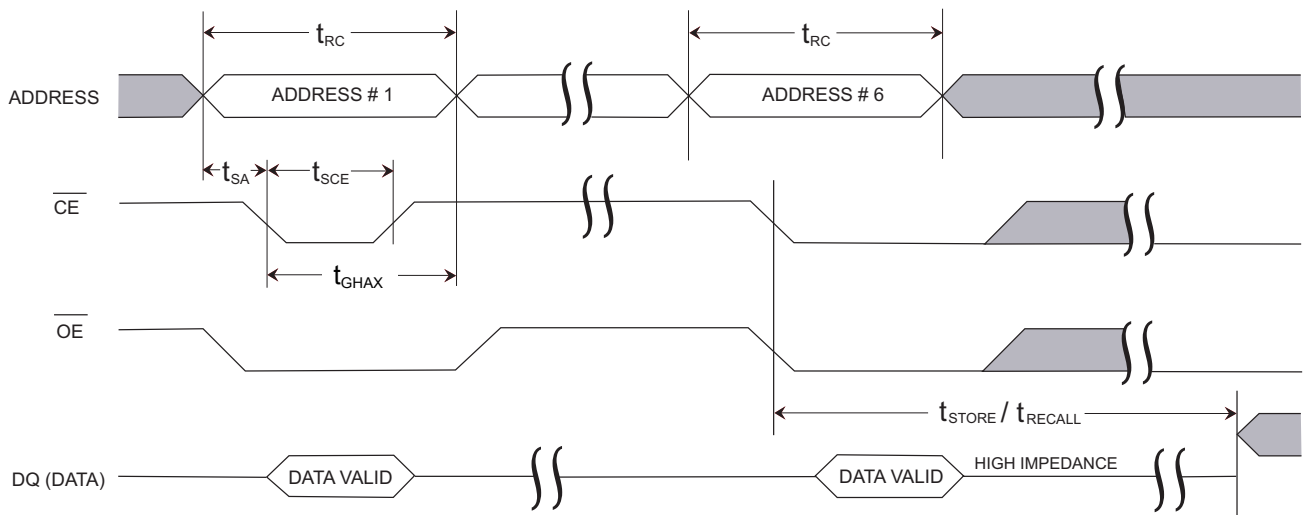

Figure 10. \overline{CE} -controlled Software STORE/RECALL Cycle [18]



Switching Waveforms (continued)

Figure 11. \overline{OE} -controlled Software STORE/RECALL Cycle [18]

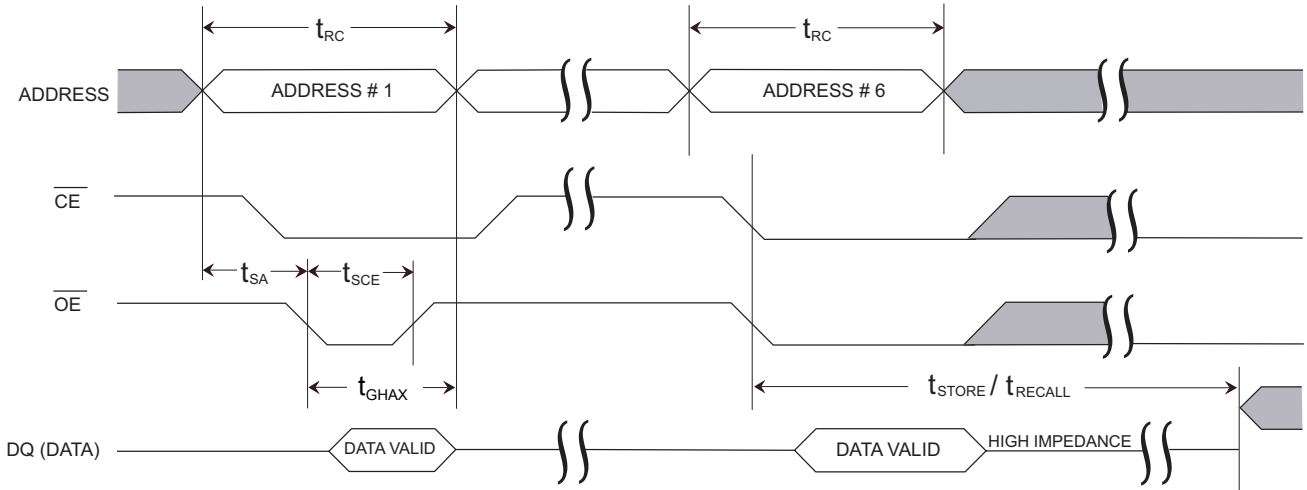

Figure 12. Soft Sequence Processing [19, 20]

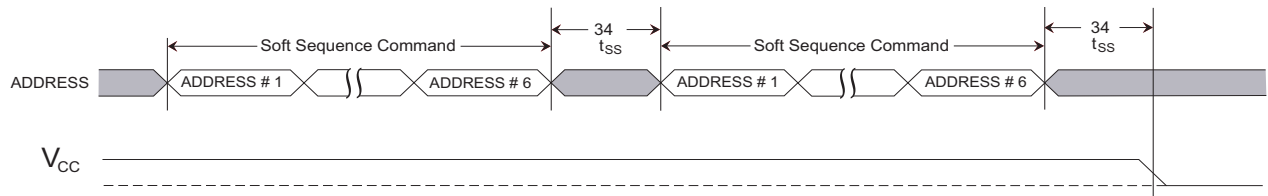
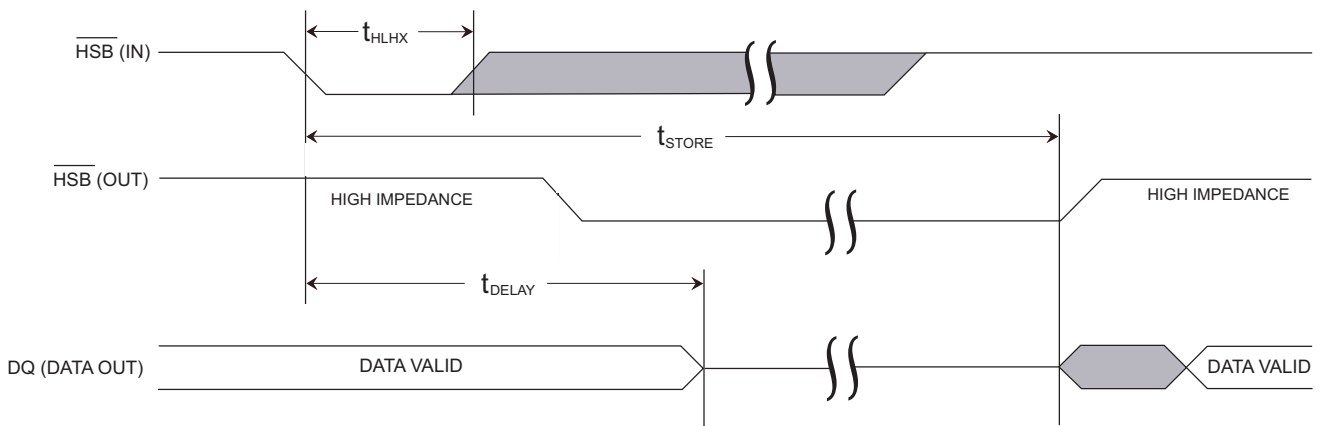
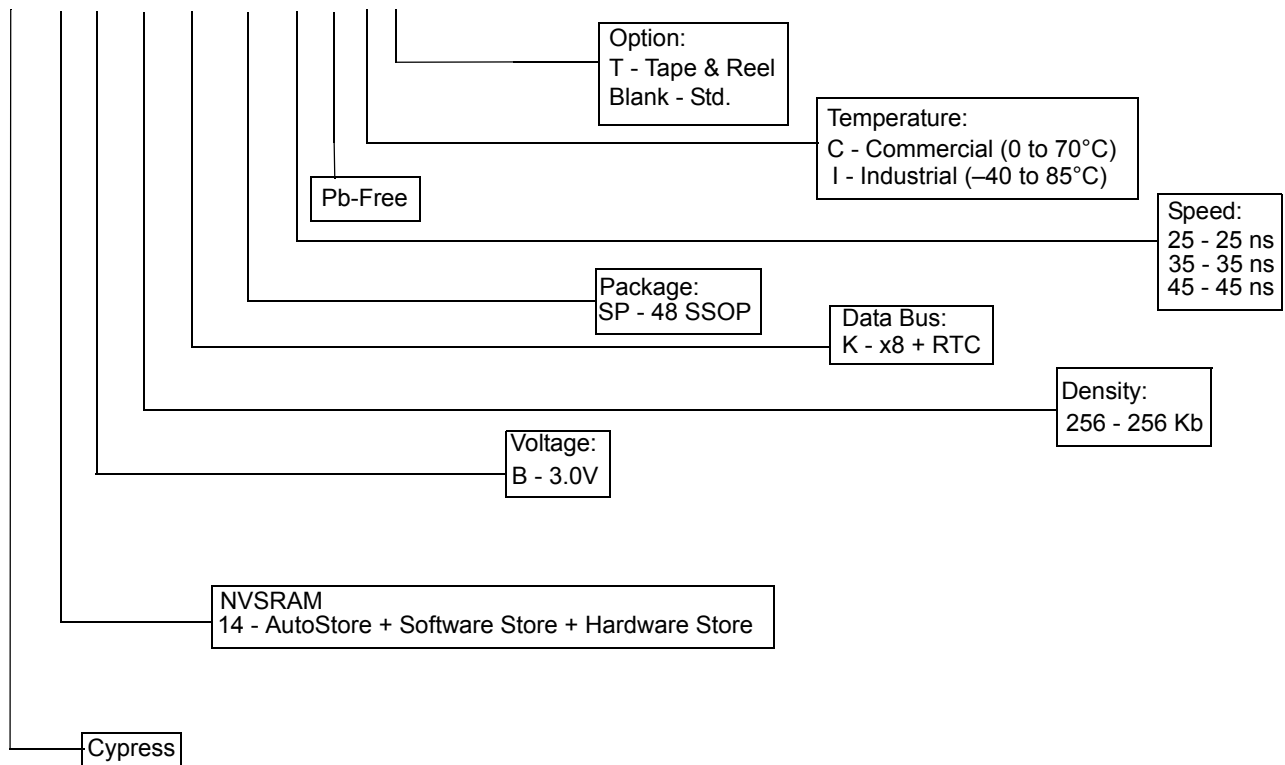

Figure 13. Hardware STORE Cycle



PART NUMBERING NOMENCLATURE
CY 14 B 256 K - SP 25 X C T

Ordering Information

All of the above mentioned parts are of "Pb-free" type. Shaded areas contain advance information. Contact your local Cypress sales representative for availability of these parts.

Speed (ns)	Ordering Code	Package Diagram	Package Type	Operating Range
25	CY14B256K-SP25XCT	51-85061	48-pin SSOP	Commercial
35	CY14B256K-SP35XCT	51-85061	48-pin SSOP	Commercial
45	CY14B256K-SP45XCT	51-85061	48-pin SSOP	Commercial
45	CY14B256K-SP45XIT	51-85061	48-pin SSOP	Industrial
	CY14B256K-SP45XI	51-85061	48-pin SSOP	

Package Diagrams

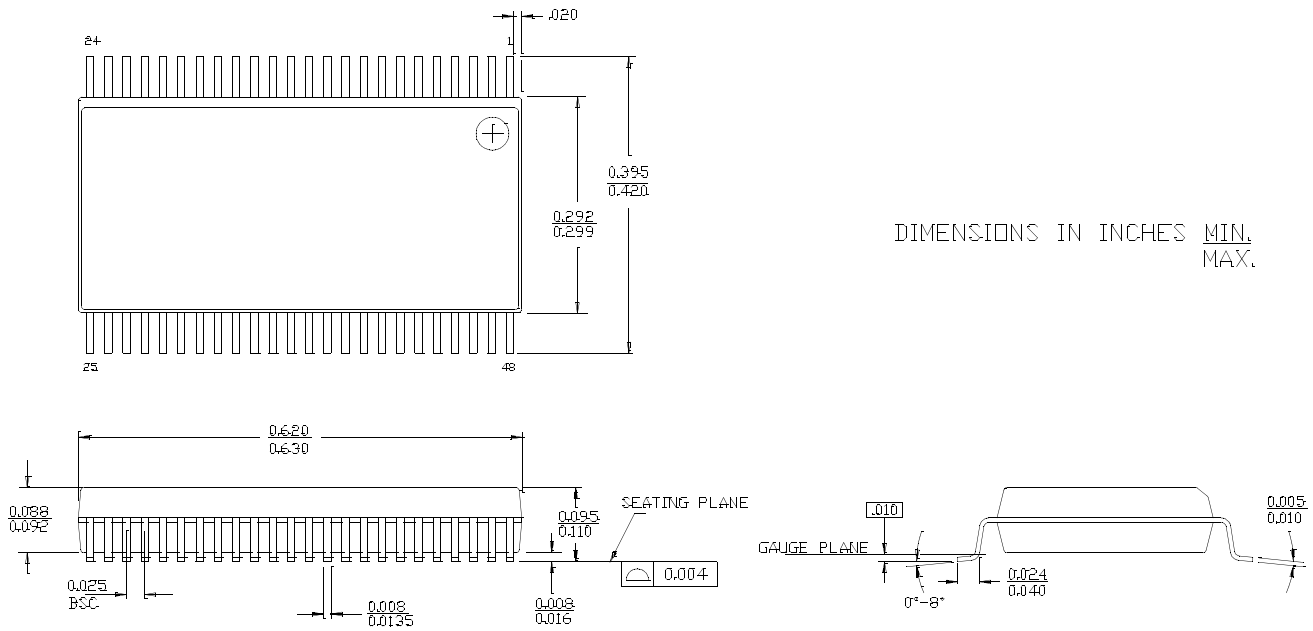
Figure 14. 48-pin Shrunk Small Outline Package, 51-85061



51-85061-C

AutoStore and QuantumTrap are registered trademarks of Simtek Corporation. All products and company names mentioned in this document are the trademarks of their respective holders.

Document History Page

Document Title: CY14B256K, 256-Kbit (32K x 8) nvSRAM with Real-Time-Clock Document Number: 001-06431				
REV.	ECN NO.	Issue Date	Orig. of Change	Description of Change
**	425138	See ECN	TUP	New Data Sheet
*A	437321	See ECN	TUP	Show Data Sheet on external Web
*B	471966	See ECN	TUP	Changed $V_{IH(MIN)}$ from 2.2V to 2.0V Changed t_{RECALL} from 60 μ s to 100 μ s Changed Endurance from 1Million Cycles to 500K Cycles Changed Data Retention from 100 Years to 20 Years Added Soft Sequence Processing Time Waveform Updated Part Numbering Nomenclature and Ordering Information Added RTC Characteristics Table Added RTC Recommended Component Configuration
*C	503277	See ECN	PCI	Changed from "Advance" to "Preliminary" Changed the term "Unlimited" to "Infinite" Changed endurance from 500K cycles to 200K cycles Device operation: Tolerance limit changed from +20% to +15% in the "Features Section" and "Operating Range Table" Removed I_{CC1} values from the DC table for 25 ns and 35 ns industrial grade Changed $V_{SWITCH(MIN)}$ from 2.55V to 2.45V Added temperature spec. to data retention - 20 years at 55°C Updated "Part Nomenclature Table" and "Ordering Information Table"
*D	597004	See ECN	TUP	Removed $V_{SWITCH(min)}$ spec from the AutoStore/Power Up RECALL table Changed t_{GLAX} spec from 20ns to 1ns Added $t_{DELAY(max)}$ spec of 70 μ s in the Hardware STORE Cycle table Removed t_{HLBL} specification Changed t_{SS} specification from 70 μ s(min) to 70 μ s(max) Changed $V_{CAP(max)}$ from 57 μ F to 120 μ F
*E	696097	See ECN	VKN	Added footnote #7 related to \overline{HSB} Added footnote #8 related to INT pin Changed t_{GLAX} to t_{GHAX} Removed ABE bit from Interrupt register